

No part of this publication may be reproduced or distributed in any form or any means, electronic, mechanical, photocopying, or otherwise without the prior permission of the author.

GATE SOLVED PAPER
Computer Science Engineering
2011

Copyright © By NODIA & COMPANY

Information contained in this book has been obtained by authors, from sources believes to be reliable. However, neither Nodia nor its authors guarantee the accuracy or completeness of any information herein, and Nodia nor its authors shall be responsible for any error, omissions, or damages arising out of use of this information. This book is published with the understanding that Nodia and its authors are supplying information but are not attempting to render engineering or other professional services.

NODIA AND COMPANY

B-8, Dhanshree Tower Ist, Central Spine, Vidyadhar Nagar, Jaipur 302039
Ph : +91 - 141 - 2101150
www.nodia.co.in
email : enquiry@nodia.co.in

GATE SOLVED PAPER - CS

2011

Q. 1 - Q. 25 carry one mark each.

- Q. 1 In a compiler, keywords of a language are recognized during
(A) parsing of the program (B) the code generation
(C) the lexical analysis of the program (D) dataflow analysis
- Q. 2 A layer-4 firewall (a device that can look at all protocol headers up to the transport layer) CANNOT
(A) block entire HTTP traffic during 9:00 PM and 5:00 AM
(B) block all ICMP traffic
(C) stop incoming traffic from a specific IP address but allow outgoing traffic to the same IP address
(D) block TCP traffic from a specific user on a multi-user system during 9:00 PM and 5:00 AM
- Q. 3 If two fair coins are flipped and at least one of the outcomes is known to be a head, what is the probability that both outcomes are heads?
(A) $1/3$ (B) $1/4$
(C) $1/2$ (D) $2/3$
- Q. 4 Consider different activities related to email.
m1: Send an email from a mail client to a mail server
m2: Download an email from mailbox server to a mail client
m3: Checking email in a web browser
Which is the application level protocol used in each activity?
(A) m1: HTTP m2: SMTP m3: POP (B) m1: SMTP m2:FTP m3: HTTP
(C) m1: SMTP m2: POP m3: HTTP (D) m1: POP m2: SMTP m3: IMAP
- Q. 5 A company needs to develop a strategy for software product development for which it has a choice of two programming language L1 and L2. The number of lines of code (LOC) developed using L2 is estimated to be twice the LOC developed with L1. The product will have to be maintained for five years. Various parameters for the company are given in the table below.

Parameter	Language L1	Language L2
Man years needed for development	LOC/10000	LOC/10000
Development Cost per man year	Rs 1000000	Rs 750000
Maintenance time	5 years	5 years
Cost of maintenance per year	Rs 100000	Rs 50000
Advertising	15000	19500
Research & Development	22000	26400

Total cost of the project includes cost of development and maintenance. What is the LOC for L1 for which the cost of the project using L1 is equal to the cost of the project using L2?

- (A) 4000 (B) 5000
(C) 4333 (D) 4667

Q. 6 Let the time taken to switch between user and kernel modes of execution be t_1 while the time taken to switch between two processes be t_2 . Which of the following is TRUE?

- (A) $t_1 > t_2$
(B) $t_1 = t_2$
(C) $t_1 < t_2$
(D) nothing can be said about the relation between t_1 and t_2

Q. 7 A company needs to develop digital signal processing software for one of its newest inventions. The software is expected to have 40000 lines of code. The company needs to determine the effort in person-months needed to develop this software using the basic COCOMO model. The multiplicative factor for this model is given as 2.8 for the software development on embedded systems, while the exponentiation factor is given as 1.20. What is the estimated effort in person months?

- (A) 234.25 (B) 932.50
(C) 287.80 (D) 122.40

Q. 8 Which of the following pairs have DIFFERENT expressive power?

- (A) Deterministic finite automata (DFA) and Non-deterministic finite automata (NFA)
(B) Deterministic push down automata (DPDA) and Non-deterministic push down automata (NPDA)
(C) Deterministic single-tape Turing machine and Non-deterministic single-tape Turing machine
(D) Single-tape Turing machine and multi-tape Turing machine

Q. 9 HTML (Hyper Text Markup Language) has language elements which permit certain actions other than describing the structure of the web document. Which one of the following actions is NOT supported by pure HTML (without any server or client side scripting) pages?

- (A) Embed web objects from different sites into the same page
(B) Refresh the page automatically after a specified interval
(C) Automatically redirect to another page upon download
(D) Display the client time as part of the page

Q. 10 Which one of the following is NOT desired in a good Software Requirement Specifications (SRS) document?

- (A) Functional Requirements
(B) Non-Functional Requirements
(C) Goals of Implementation
(D) Algorithms for Software Implementation

Q. 11 A computer handles several interrupt sources of which the following are relevant for this question.

- * Interrupt from CPU temperature sensor (raises interrupt if CPU temperature is too high)
- * Interrupt from Mouse (raises interrupt if the mouse is moved or a button is pressed)
- * Interrupt from Keyboard (raises interrupt when a key is pressed or released)
- * Interrupt from Hard Disk (raises interrupt when a disk read is completed)

Which one of these will be handled at the HIGHEST priority?

- (A) Interrupt from Hard Disk
 (B) Interrupt from Mouse
 (C) Interrupt from Keyboard
 (D) Interrupt from CPU temperature sensor

Q. 12 Consider a relational table with a single record for each registered student with the following attributes.

1. Registration_Num: Unique registration number of each registered student
2. UID: Unique identity number, unique at the national level for each citizen
3. BankAccount_Num: Unique account number at the bank. A student can have multiple accounts or joint accounts. This attribute stores the primary account number.
4. Name: Name of the student
5. Hostel_Room: Room number of the hostel

Which of the following options is INCORRECT?

- (A) BankAccount_Num is a candidate key
 (B) Registration_Num can be a primary key
 (C) UID is a candidate key if all students are from the same country
 (D) If S is a superkey such that $S \cap UID$ is NULL then $S \cup UID$ is also a superkey

Q. 13 Which one of the following circuits is NOT equivalent to a 2-input XNOR (exclusive NOR) gate?

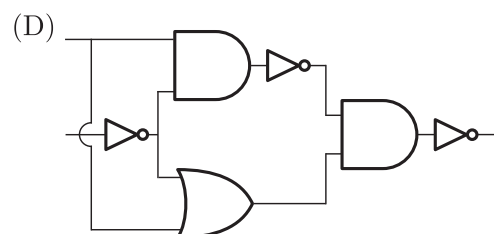
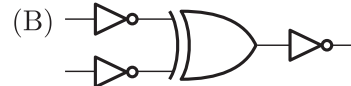

Q. 14 The simplified SOP (Sum of Product) form of the Boolean expression

$(P + \bar{Q} + \bar{R}).(P + \bar{Q} + R).(P + Q + \bar{R})$ is

- (A) $(\bar{P}.Q + \bar{R})$ (B) $(P + \bar{Q}.\bar{R})$
 (C) $(\bar{P}.Q + R)$ (D) $(P.Q + R)$

- Q. 15 The minimum number of D flip-flops needed to design a mod-258 counter is
 (A) 9 (B) 8
 (C) 512 (D) 258
- Q. 16 A thread is usually defined as a “light weight process” because an operating system (OS) maintains smaller data structures for a thread than for a process. In relation to this, which of the following is TRUE?
 (A) On per-thread basis, the OS maintains only CPU register state
 (B) The OS does not maintain a separate stack for each thread
 (C) On per-thread basis, the OS does not maintain virtual memory state
 (D) On per-thread basis, the OS maintains only scheduling and accounting information

- Q. 17 K4 and Q3 are graphs with the following structures.

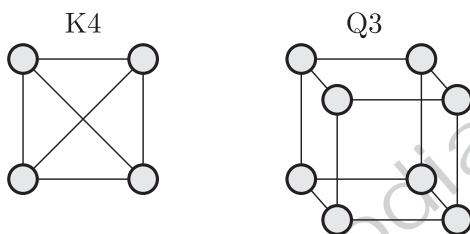

Which one of the following statements is TRUE in relation to these graphs?

- (A) K4 is planar while Q3 is not
 (B) Both K4 and Q3 are planar
 (C) Q3 is planar while K3 is not
 (D) Neither K4 nor Q3 is planar
- Q. 18 If the difference between the expectation of the square of a random variable ($E[X^2]$) and the square of the expectation of the random variable ($(E[X])^2$) is denoted by R , then
 (A) $R = 0$ (B) $R < 0$
 (C) $R \geq 0$ (D) $R > 0$
- Q. 19 The lexical analysis for a modern computer language such as Java needs the power of which one of the following machine models in a necessary and sufficient sense?
 (A) Finite state automata
 (B) deterministic pushdown automata
 (C) Non-deterministic pushdown automata
 (D) Turing machine
- Q. 20 Let the page fault service time be 10 ms in a computer with average memory access time being 20 ns. If one page fault is generated for every 10^6 memory accesses, what is the effective access time for the memory?
 (A) 21 ns (B) 30 ns
 (C) 23 ns (D) 35 ns

- Q. 21 Consider a hypothetical processor with an instruction of type $LW\ R1, 20(R2)$, which during execution reads a 32-bit word from memory and stores it in a 32-bit register R1. The effective address of the memory location is obtained by the addition of a constant 20 and the contents of register R2. Which of the following best reflects the addressing mode implemented by this instruction for the operand in memory?
 (A) Immediate Addressing (B) Register Addressing
 (C) Register Indirect Scaled Addressing (D) Base Indexed Addressing

- Q. 22 What does the following fragment of C program print?

```
Char c[] = "GATE2011";
char *p = c;
printf("%s", p + p[3] - p[1]);
```

 (A) GATE2011 (B) E2011
 (C) 2011 (D) 011

- Q. 23 A max-heap is a heap where the value of each parent is greater than or equal to the value of its children. Which of the following is a max-heap?

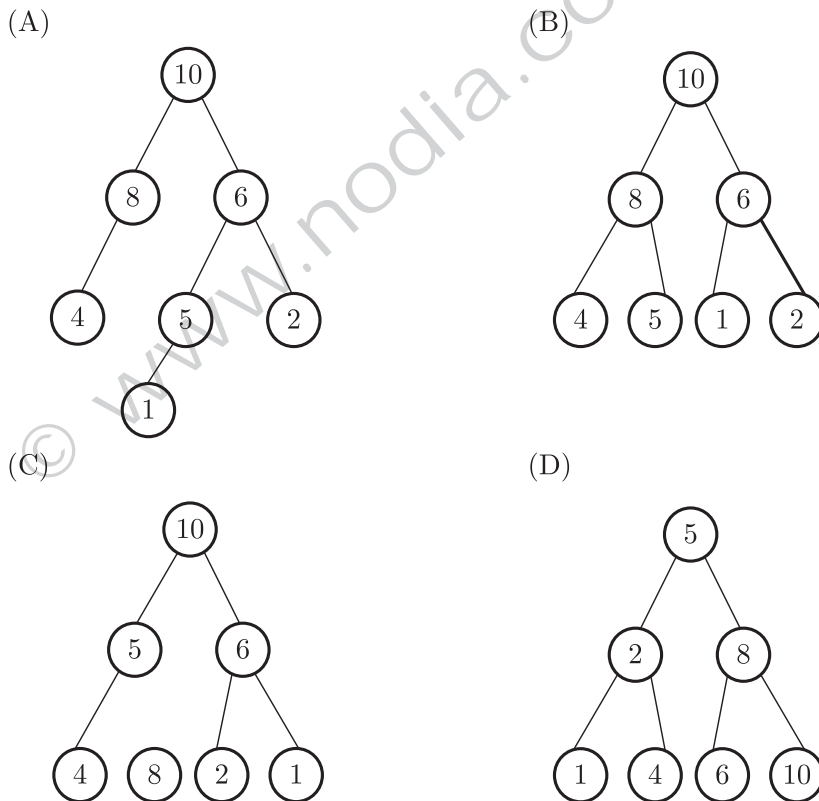

- Q. 24 Let P be a regular language and Q be a context-free language such that $Q \subseteq P$. (For example, let P be the language represented by the regular expression p^*q^* and Q be $\{p^nq^n \mid n \in N\}$). Then which of the following is ALWAYS regular?
 (A) $P \cap Q$ (B) $P - Q$
 (C) $\Sigma^* - P$ (D) $\Sigma^* - Q$

- Q. 25 An algorithm to find the length of the longest monotonically increasing sequence of numbers in an array $A[0:n-1]$ is given below.
Let L_i denote the length of the longest monotonically increasing sequence starting at index i in the array.

Initialize $L_{n-1} = 1$

For all i such that $0 \leq i \leq n-2$

$$L_i = \begin{cases} 1 + L_{i+1} & \text{if } A[i] < A[i+1] \\ 1 & \text{Otherwise} \end{cases}$$

Finally the length of the longest monotonically increasing sequence is $\max(L_0, L_1, \dots, L_{n-1})$. Which of the following statements is TRUE?

- (A) The algorithm uses dynamic programming paradigm
- (B) The algorithm has a linear complexity and uses branch and bound paradigm
- (C) The algorithm has a non-linear polynomial complexity and uses branch and bound paradigm
- (D) The algorithm uses divide and conquer paradigm.

Q. 26 to Q. 55 carry two marks each.

- Q. 26 Consider the languages L_1 , L_2 and L_3 as given below.
 $L_1 = \{0^p 1^q \mid p, q \in N\}$,
 $L_2 = \{0^p 1^q \mid p, q \in N \text{ and } p = q\}$ and
 $L_3 = \{0^p 1^q \mid p, q, r \in N \text{ and } p = q = r\}$. Which of the following statements is NOT TRUE?
- (A) Push Down Automata (PDA) can be used to recognize L_1 and L_2
 - (B) L_1 is a regular language
 - (C) All the three languages are context free
 - (D) Turing machines can be used to recognize all the languages

- Q. 27 Consider two binary operators ' \uparrow ' and ' \downarrow ' with the precedence of operator \downarrow being lower than that of the operator \uparrow . Operator \uparrow is right associative while operator \downarrow is left associative. Which one of the following represents the parse tree for expression $(7 \downarrow 3 \uparrow 4 \uparrow 3 \downarrow 2)$?

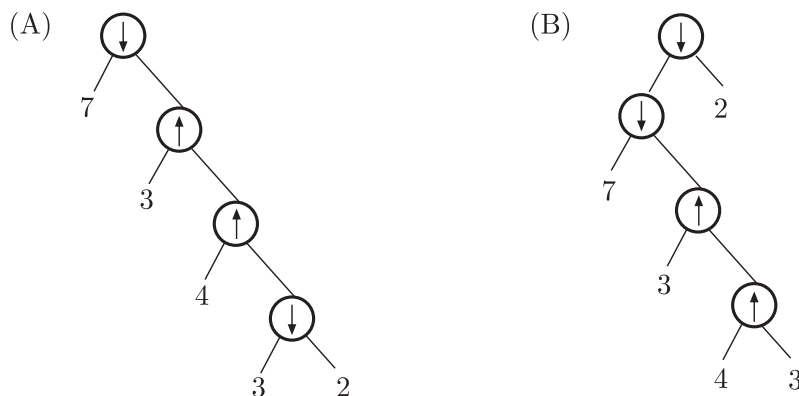

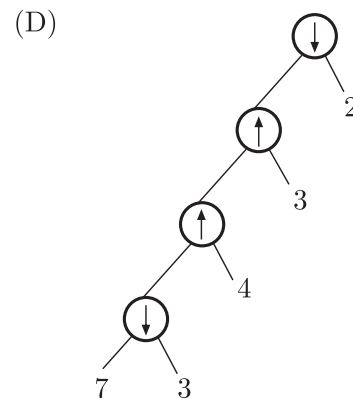
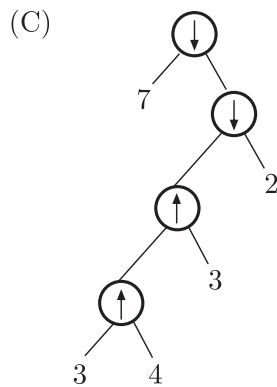

Q. 28

On a non-pipelined sequential processor, a program segment, which is a part of the interrupt service routine, is given to transfer 500 bytes from an I/O device to memory.

```

Initialize the address register
Initialize the count to 500
LOOP:Load a byte from device
Store in memory at address given by address register
Increment the address register
Decrement the count
If count != 0 go to LOOP
    
```

Assume that each statement in this program is equivalent to a machine instruction which takes one clock cycle to execute if it is a non-load/store instruction. The load-store instructions take two clock cycles to execute.

The designer of the system also has an alternate approach of using the DMA controller to implement the same transfer. The DMA controller requires 20 clock cycles for initialization and other overheads. Each DMA transfer cycle takes two clock cycles to transfer one byte of data from the device to the memory.

What is the approximate speedup when the DMA controller based design is used in place of the interrupt driven program based input-output?

- (A) 3.4
- (B) 4.4
- (C) 5.1
- (D) 6.7

Q. 29

We are given a set of n distinct elements and an unlabeled binary tree with n nodes. In how many ways can we populate the tree with the given set so that it becomes a binary search tree?

- (A) 0
- (B) 1
- (C) $n!$
- (D) $\frac{1}{n+1} \cdot {}^{2n}C_n$

Q. 30

Which one of the following options is CORRECT given three positive integers x , y and z , and a predicate

$$P(x) = \neg(x = 1) \wedge \forall y(\exists z(x = y * z) \Rightarrow (y = x) \vee (y = 1))$$

- (A) $P(x)$ being true means that x is a prime number
- (B) $P(x)$ being true means that x is a number other than 1
- (C) $P(x)$ is always true irrespective of the value of x
- (D) $P(x)$ being true means that x has exactly two factors other than 1 and x

Q. 31 Given $i = \sqrt{-1}$, what will be the evaluation of the definite integral $\int_0^{\pi/2} \frac{\cos x + i \sin x}{\cos x - i \sin x} dx$?

- (A) 0 (B) 2
(C) $-i$ (D) i

Q. 32 Consider a database table T containing two columns X and Y each of type integer. After the creation of the table, one record ($X = 1, Y = 1$) is inserted in the table.

Let MX and MY denote the respective maximum values of X and Y among all records in the table at any point in time. Using MX and MY , new records are inserted in the table 128 times with X and Y values being $MX + 1, 2 * MY + 1$ respectively. It may be noted that each time after the insertion, values of MX and MY change. What will be the output of the following SQL query after the steps mentioned above are carried out?

SELECT Y FROM T WHERE X = 7;

- (A) 127 (B) 255
(C) 129 (D) 257

Q. 33 Consider a finite sequence of random values $X = [x_1, x_2, \dots, x_n]$. Let μ_x be the mean and σ_x be the standard deviation of X . Let another finite sequence Y of equal length be derived from this as $y_i = a * x_i + b$, where a and b are positive constants. Let μ_y be the mean and σ_y be the standard deviation of this sequence. Which one of the following statements is INCORRECT?

- (A) Index position of mode of X in X is the same as the index position of mode of Y in Y .
(B) Index position of median of X in X is the same as the index position of median of Y in Y .
(C) $\mu_y = a\mu_x + b$ (D) $\sigma_y = a\sigma_x + b$

Q. 34 A deck of 5 cards (each carrying a distinct number from 1 to 5) is shuffled thoroughly. Two cards are then removed one at a time from the deck. What is the probability that the two cards are selected with the number on the first card being one higher than the number on the second card?

- (A) $1/5$ (B) $4/25$
(C) $1/4$ (D) $2/5$

Q. 35 Consider the following table of arrival time and burst time for three processes P0, P1 and P2.

Process	Arrival time	Burst Time
P0	0 ms	9 ms
P1	1 ms	4 ms
P2	2 ms	9 ms

The pre-emptive shortest job first scheduling algorithm is used. Scheduling is carried out only at arrival or completion of processes. What is the average waiting time for the three processes?

- (A) 5.0 ms (B) 4.33 ms
(C) 6.33 ms (D) 7.33 ms

- Q. 36 Consider evaluating the following expression tree on a machine with load-store architecture in which memory can be accessed only through load and store instructions. The variables a , b , c , d and e are initially stored in memory. The binary operators used in this expression tree can be evaluated by the machine only when the operands are in registers. The instructions produce result only in a register. If no intermediate results can be stored in memory, what is the minimum number of registers needed to evaluate this expression?

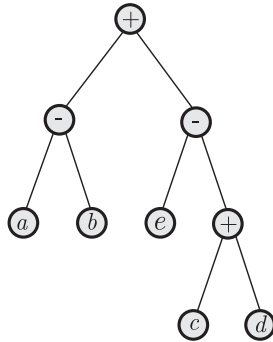

- (A) 2
(B) 9
(C) 5
(D) 3
- Q. 37 Which of the given options provides the increasing order of asymptotic complexity of functions f_1 , f_2 , f_3 and f_4 ?
 $f_1(n) = 2^n$ $f_2(n) = n^{3/2}$ $f_3(n) = n \log_2 n$ $f_4(n) = n^{\log_2 n}$
 (A) f_3, f_2, f_4, f_1 (B) f_3, f_2, f_1, f_4
 (C) f_2, f_3, f_1, f_4 (D) f_2, f_3, f_4, f_1
- Q. 38 Four matrices M_1 , M_2 , M_3 and M_4 of dimensions $p \times q$, $q \times r$, $r \times s$ and $s \times t$ respectively can be multiplied in several ways with different number of total scalar multiplications. For example when multiplied as $((M_1 \times M_2) \times (M_3 \times M_4))$, the total number of scalar multiplications is $pqr + rst + prt$. When multiplied as $((M_1 \times M_2) \times M_3) \times M_4$, the total number of scalar multiplications is $pqr + prs + pst$. If $p = 10$, $q = 100$, $r = 20$, $s = 5$, and $t = 80$, then the minimum number of scalar multiplications needed is
 (A) 248000 (B) 44000
 (C) 19000 (D) 25000
- Q. 39 Consider a relational table r with sufficient number of records, having attributes A_1, A_2, \dots, A_n and let $1 \leq p \leq n$. Two queries Q1 and Q2 are given below.
 Q1: $\pi_{A_1, \dots, A_p}(\sigma_{A_p=c}(r))$ where c is a constant
 Q2: $\pi_{A_1, \dots, A_p}(\sigma_{c_1 \leq A_p \leq c_2}(r))$ where c_1 and c_2 are constants
 The database can be configured to do ordered indexing on A_p or hashing on A_p . Which of the following statements is TRUE?
 (A) Ordered indexing will always outperform hashing for both queries
 (B) Hashing will always outperform ordered indexing for both queries
 (C) Hashing will outperform ordered indexing on Q1, but not on Q2
 (D) Hashing will outperform ordered indexing on Q2, but not on Q1

Q. 40 Consider the matrix as given below.

$$\begin{bmatrix} 1 & 2 & 3 \\ 0 & 4 & 7 \\ 0 & 0 & 3 \end{bmatrix}$$

Which one of the following options provides the CORRECT values of the eigenvalues of the matrix?

- (A) 1, 4, 3 (B) 3, 7, 3
(C) 7, 3, 2 (D) 1, 2, 3

Q. 41 Consider an instruction pipeline with four stages (S1, S2, S3 and S4) each with combinational circuit only. The pipeline registers are required between each stage and at the end of the last stage. Delays for the stages and for the pipeline registers are as given in the figure.

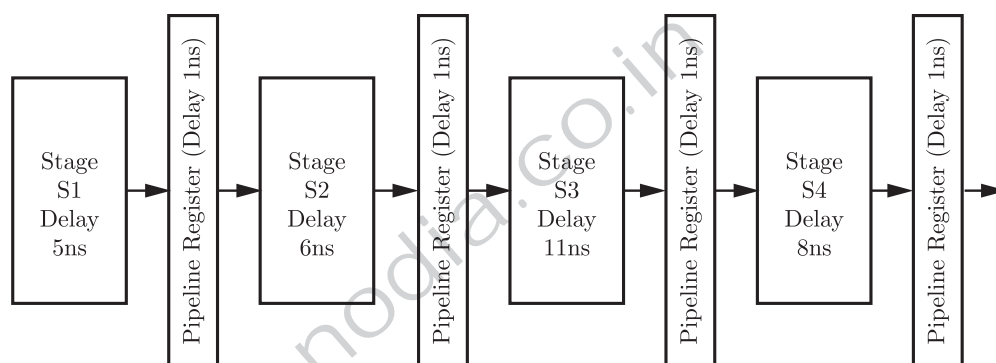

What is the approximate speed up of the pipeline in steady state under ideal conditions when compared to the corresponding non-pipeline implementation?

- (A) 4.0 (B) 2.5
(C) 1.1 (D) 3.0

Q. 42 Definition of a language L with alphabet $\{a\}$ is given as following.

$$L = \{a^{nk} \mid k > 0, \text{ and } n \text{ is a positive integer constant}\}$$

What is the minimum number of states needed in a DFA to recognize L ?

- (A) $k + 1$ (B) $n + 1$
(C) 2^{n+1} (D) 2^{k+1}

Q. 43 An 8 KB direct-mapped write-back cache is organized as multiple blocks, each of size 32-bytes. The processor generates 32-bit addresses. The cache controller maintains the tag information for each cache block comprising of the following.

- 1 Valid bit
- 1 Modified bit

As many bits as the minimum needed to identify the memory block mapped in the cache.

What is the total size of memory needed at the cache controller to store meta-data (tags) for the cache?

- (A) 4864 bits (B) 6144 bits
(C) 6656 bits (D) 5376 bits

- Q. 44 An application loads 100 libraries at startup. Loading each library requires exactly one disk access. The seek time of the disk to a random location is given as 10 ms. Rotational speed of disk is 6000 rpm. If all 100 libraries are loaded from random locations on the disk, how long does it take to load all libraries? (The time to transfer data from the disk block once the head has been positioned at the start of the block may be neglected.)
- (A) 0.50 s (B) 1.50 s
(C) 1.25 s (D) 1.00 s

- Q. 45 A deterministic finite automation (DFA) D with alphabet $\Sigma = \{a, b\}$ is given below.

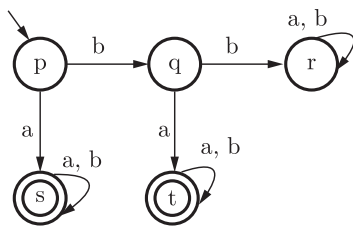

Which of the following finite state machines is a valid minimal DFA which accepts the same language as D ?

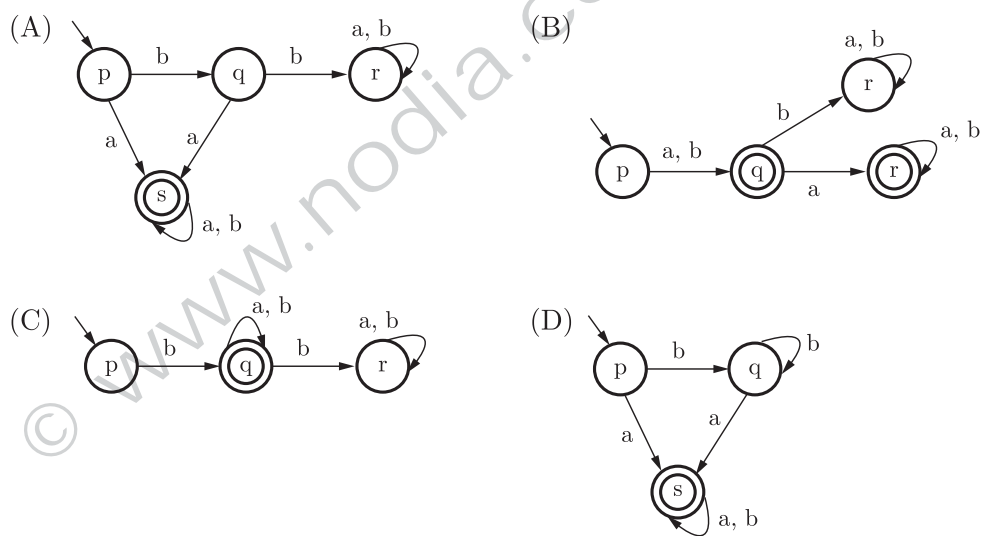

- Q. 46 Database table by name Loan_Records is given below.

Borrower	Bank_Manager	Loan_Amount
Ramesh	Sunderajan	10000.00
Suresh	Ramgopal	5000.00
Mahesh	Sunderajan	7000.00

What is the output of the following SQL query?

```
SELECT count(*)
FROM (
    (SELECT Borrower, Bank_Manager FROM Loan_Records) AS S
    NATURAL JOIN
    (SELECT Bank_Manager, Loan_Amount FROM Loan_Records) AS T
);
```

- (A) 3 (B) 9
(C) 5 (D) 6

Q. 47

The following is the comment written for a C function.

```

/* This function computes the roots of a quadratic equation
a.x^2 + b.x + c = 0. The function stores two real roots
in *root1 and *root2 and returns the status of validity
of roots. It handles four different kinds of cases.
(i) When coefficient a is zero irrespective of discriminant
(ii) When discriminant is positive
(iii) When discriminant is zero
(iv) When discriminant is negative.
Only in case (ii) and (iii), the stored roots are valid.
Otherwise 0 is stored in the roots. The function returns
0 when the roots are valid and -1 otherwise.
The function also ensures root1 >= root2.
int get_QuadRoots (float a, float b, float c,
float *root1, float *root2);
*/

```

A software test engineer is assigned the job of doing black box testing. He comes up with the following test cases, many of which are redundant.

Test Case	Input Set			Expected Output Set		
	a	b	c	root1	root2	Return Value
T1	0.0	0.0	7.0	0.0	0.0	-1
T2	0.0	1.0	3.0	0.0	0.0	-1
T3	1.0	2.0	1.0	-1.0	-1.0	0
T4	4.0	-12.0	9.0	1.5	1.5	0
T5	1.0	-2.0	-3.0	3.0	-1.0	0
T6	1.0	1.0	4.0	0.0	0.0	-1

Which one of the following options provide the set of non-redundant tests using equivalence class partitioning approach from input perspective for black box testing?

- (A) T1, T2, T3, T6 (B) T1, T3, T4, T5
(C) T2, T4, T5, T6 (D) T2, T3, T4, T5

Common Data Questions

Common Data For Q. 48 and 49 :

Consider the following recursive C function that takes two arguments.

```

unsigned int foo (unsigned int n, unsigned int r) {
    if (n>0) return ((n%r) + foo (n/r, r));
    else return 0;
}

```

- Q. 48 What is the return value of the function `foo` when it is called as `foo(345, 10)`?
 (A) 345 (B) 12
 (C) 5 (D) 3
- Q. 49 What is the return value of the function `foo` when it is called as `foo(513, 2)`?
 (A) 9 (B) 8
 (C) 5 (D) 2

Common Data For Q. 50 and 51 :

Consider the following circuit involving three D-type flip-flops used in a certain type of counter configuration.

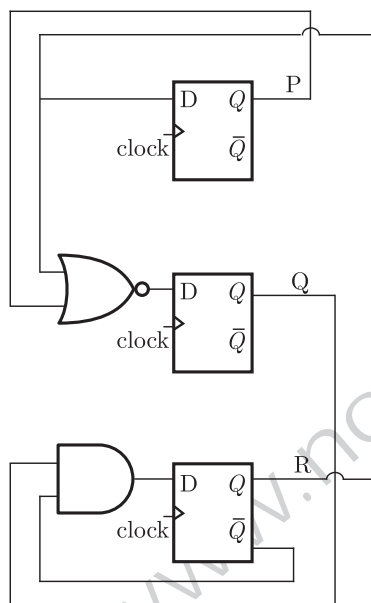

- Q. 50 If at some instance prior to the occurrence of the clock edge, P , Q and R have a value 0, 1 and 0 respectively, what shall be the value of PQR after the clock edge?
 (A) 000 (B) 001
 (C) 010 (D) 011
- Q. 51 If all the flip-flops were reset to 0 at power on, what is the total number of distinct outputs (states) represented by PQR generated by the counter?
 (A) 3 (B) 4
 (C) 5 (D) 6

Linked Answer Questions

Statement For Linked Q. 52 and 53 :

Consider a network with five nodes, N_1 to N_5 , as shown below.

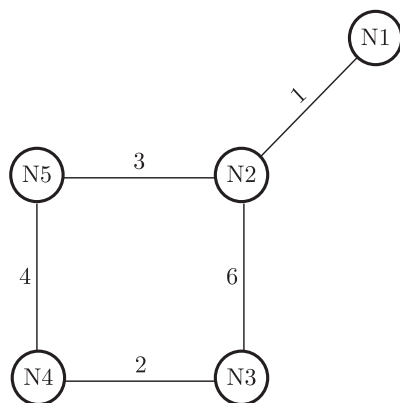

The network uses a Distance Vector Routing protocol. Once the routes have stabilized, the distance vectors at different nodes are as following.

N1: (0, 1, 7, 8, 4)

N2: (1, 0, 6, 7, 3)

N3: (7, 6, 0, 2, 6)

N4: (8, 7, 2, 0, 4)

N5: (4, 3, 6, 4, 0)

Each distance vector is the distance of the best known path at that instance to nodes, N1 to N5, where the distance to itself is 0. Also, all links are symmetric and the cost is identical in both directions. In each round, all nodes exchange their distance vectors with their respective neighbors. Then all nodes update their distance vectors. In between two rounds, any change in cost of a link will cause the two incident nodes to change only that entry in their distance vectors.

Q. 52

The cost of link N2-N3 reduces to 2 (in both directions). After the next round of updates, what will be the new distance vector at node, N3?

(A) (3, 2, 0, 2, 5)

(B) (3, 2, 0, 2, 6)

(C) (7, 2, 0, 2, 5)

(D) (7, 2, 0, 2, 6)

Q. 53

After the update in the previous question, the link N1-N2 goes down. N2 will reflect this change immediately in its distance vector as cost, ∞ . After the NEXT ROUND of update, what will be the cost to N1 in the distance vector of N3?

(A) 3

(B) 9

(C) 10

(D) ∞

Statement For Linked Q. 54 and 55 :

An undirected graph $G(V, E)$ contains $n(n > 2)$ nodes named v_1, v_2, \dots, v_n . Two nodes v_i, v_j are connected if and only if $0 < i - j \leq 2$. Each edge (v_i, v_j) is assigned a weight $i + j$. A sample graph with $n = 4$ is shown below.

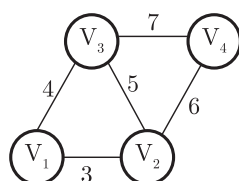

- Q. 54 What will be the cost of the minimum spanning tree (MST) of such a graph with n nodes?
 (A) $\frac{1}{12}(11n^2 - 5n)$ (B) $n^2 - n + 1$
 (C) $6n - 11$ (D) $2n + 1$
- Q. 55 The length of the path from v_5 to v_6 in the MST of previous question with $n = 10$ is
 (A) 11 (B) 25
 (C) 31 (D) 41

General Aptitude (GA) Questions

Q. 56 - Q. 60 Carry one mark each.

- Q. 56 Which of the following options is the closest in the meaning to the word below:
Inexplicable
 (A) Incomprehensible (B) Indelible
 (C) Inextricable (D) Infallible
- Q. 57 If $\text{Log}(P) = (1/2)\text{Log}(Q) = (1/3)\text{Log}(R)$, then which of the following options is TRUE?
 (A) $P^2 = Q^3 R^2$ (B) $Q^2 = PR$
 (C) $Q^2 = R^3 P$ (D) $R = P^2 Q^2$
- Q. 58 Choose the most appropriate word(s) from the options given below to complete the following sentence.
I contemplated _____ Singapore for my vacation but decided against it.
 (A) to visit (B) having to visit
 (C) visiting (D) for a visit
- Q. 59 Choose the most appropriate word from the options given below to complete the following sentence.
If you are trying to make a strong impression on your audience, you cannot do so by being understated, tentative or _____.
 (A) hyperbolic (B) restrained
 (C) argumentative (D) indifferent
- Q. 60 Choose the word from the options given below that is most nearly opposite in meaning to the given word:
Amalgamate
 (A) merge (B) split
 (C) collect (D) separate

Q. 61 to Q. 65 carry two marks each.

- Q. 61 **Few school curricula include a unit on how to deal with bereavement and grief, and yet all students at some point in their lives suffer from losses through death and parting.**

Based on the above passage which topic would not be included in a unit on bereavement?

- (A) how to write a letter of condolence
 (B) what emotional stages are passed through in the healing process
 (C) what the leading causes of death are
 (D) how to give support to a grieving friend

- Q. 62 P, Q, R and S are four types of dangerous microbes recently found in a human habitat. The area of each circle with its diameter printed in brackets represents the growth of a single microbe surviving human immunity system within 24 hours of entering the body. The danger to human beings varies proportionately with the toxicity, potency and growth attributed to a microbe shown in the figure below:

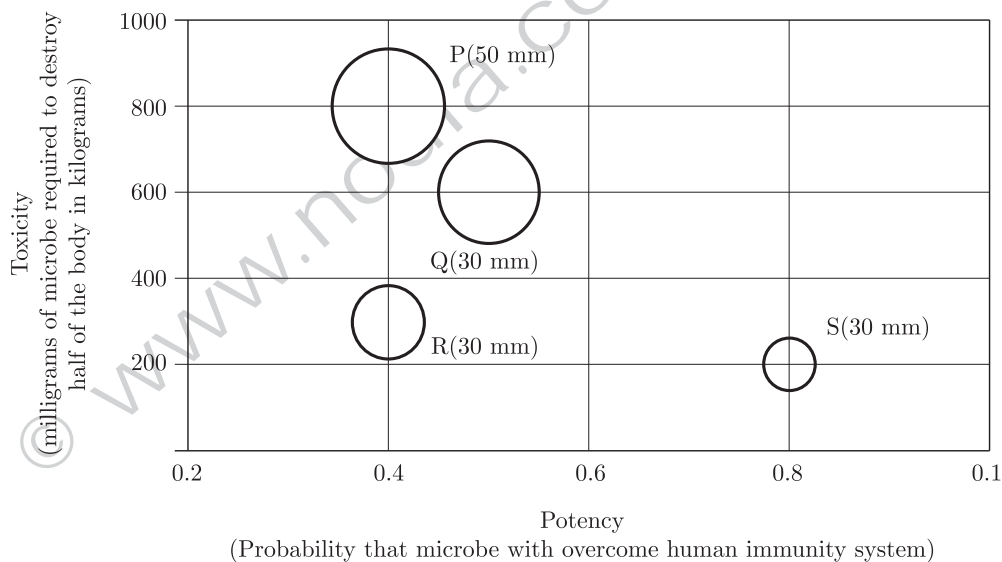

A pharmaceutical company is contemplating the development of a vaccine against the most dangerous microbe. Which microbe should the company target in its first attempt?

- (A) P (B) Q
 (C) R (D) S

- Q. 63 The variable cost (V) of manufacturing a product varies according to the equation $V = 4q$, where q is the quantity produced. The fixed cost (F) of production of same product reduces with q according to the equation $F = 100/q$. How many units should be produced to minimize the total cost ($V + F$)?

- (A) 5 (B) 4
 (C) 7 (D) 6

- Q. 64 A transporter receives the same number of orders each day. Currently, he has some pending orders (backlog) to be shipped. If he uses 7 trucks, then at the end of the 4th day he can clear all the orders. Alternatively, if he uses only 3 trucks, then all the orders are cleared at the end of the 10th day. What is the minimum number of trucks required so that there will be no pending order at the end of the 5th day?
- (A) 4 (B) 5
(C) 6 (D) 7
- Q. 65 A container originally contains 10 litres of pure spirit. From this container 1 litre of spirit is replaced with 1 litre of water. Subsequently, 1 litre of the mixture is again replaced with 1 litre of water and this process is repeated one more time. How much spirit is now left in the container?
- (A) 7.58 litres (B) 7.84 litres
(C) 7 litres (D) 7.29 litres

ANSWER KEY

2011									
1	2	3	4	5	6	7	8	9	10
(C)	(A)	(A)	(C)	(B)	(C)	(A)	(B)	(D)	(D)
11	12	13	14	15	16	17	18	19	20
(D)	(A)	(D)	(B)	(A)	(A)	(B)	(C)	(A)	(B)
21	22	23	24	25	26	27	28	29	30
(D)	(C)	(B)	(C)	(A)	(C)	(C)	(A)	(D)	(A)
31	32	33	34	35	36	37	38	39	40
(D)	(A)	(D)	(A)	(A)	(D)	(A)	(C)	(A)	(A)
41	42	43	44	45	46	47	48	49	50
(B)	(B)	(D)	(B)	(A)	(C)	(C)	(B)	(D)	(D)
51	52	53	54	55	56	57	58	59	60
(B)	(A)	(C)	(B)	(C)	(A)	(B)	(C)	(B)	(B)
61	62	63	64	65					
(C)	(D)	(A)	(C)	(D)					

© www.nodia.com